

Data subject to change without prior notice
Edition 10/2022 © 2022 JMG Cranes S.p.A. All rights reserved
Rev. 2 - 10/22



LIGE by JMG Cranes S.p.A.

Sales & Service Office

Via Bergamo, 142

26100 Cremona - Italy

t +39 0372 1786738

Production Plant

Via Zuccherificio 2

29010 Sarmato (PC) - Italy

t +39 0523 8486

e info@jmgcranes.com



www.jmgcranes.com

ELECTRIC PICK & CARRY CRANES



L40 (metric)
Max Capacity 4.000 kg

LIGE
SINCE 1945 by JMG

WIDE AND ERGONOMIC CABIN
 FRONT WHEELS DRIVE WITH COUNTER ROTATION
 COMPACTNESS AND AGILITY
 REAR STEERING

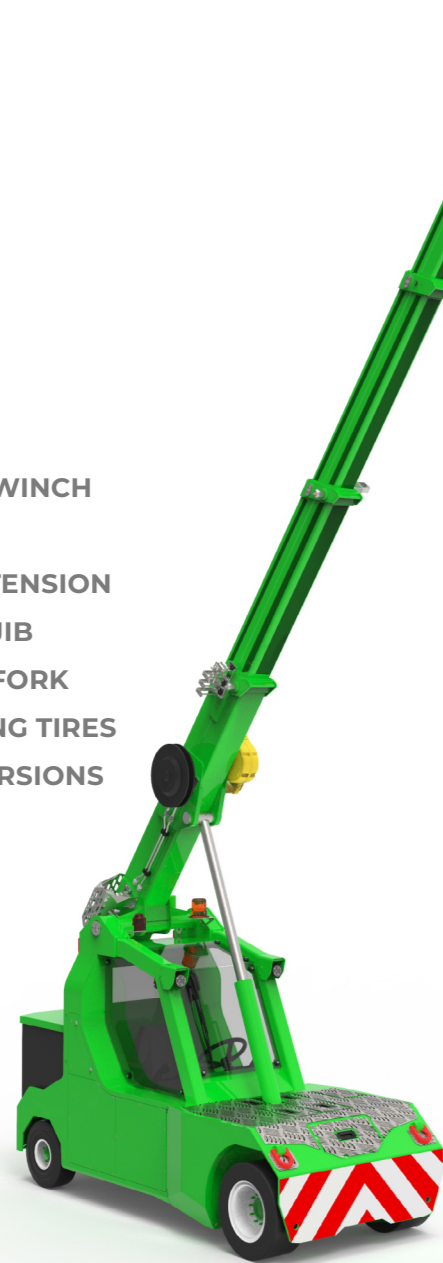

Optionals:

- HYDRAULIC WINCH
- MANUAL JIB
- MANUAL EXTENSION
- HYDRAULIC JIB
- HYDRAULIC FORK
- NON-MARKING TIRES
- ATEX CONVERSIONS

Technical features

Max Capacity kg	4,000	Front-wheels drive. N°2 electric motors AC 3 kW 48V. Insulation class H	L.M.L. Electronic safe load indicator and tilting moment limiter
	Dimensions mm	3100x1300x2215	Service brake: hydraulic with foot control. Parking and emergency brake: hydraulic with automatic control.
Max Capacity kg		48 V - 630 Ah 8 working hours	Self-supporting steel structure bent and welded
	Dimensions mm	Front nr. 2 superelastic 23x10x12 Rear nr. 2 superelastic 18x7x8	+55°/-17°
Max Capacity kg		Rear Steering angle -90°/+90°	Motor driven pump 9 kW - 48 V AC, Insulation class H

Load charts

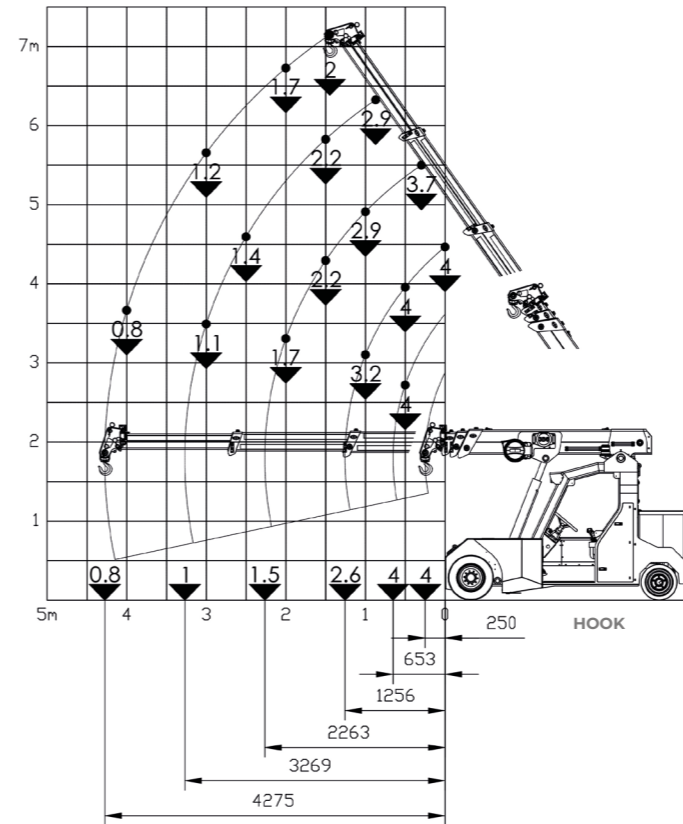

EU Standards CE

	UNI ISO 4301-1: A1
	2006/42 CE-2014/30 UE-2014/35 UE- 2000/14 and subsequent modifications
	EN 13000:2014 ANSI/ASME B30.5-2011 and subsequent modifications

Dimensions

