

Data subject to change without prior notice  
Edition 10/2022 © 2022 JMG Cranes S.p.A. All rights reserved  
Rev. 2 - 10/22

## JMG Cranes S.p.A.

Sales & Service Office

Via Bergamo, 142

26100 Cremona - Italy

t +39 0372 1786738

Production Plant

Via Zuccherificio 2

29010 Sarmato (PC) - Italy

t +39 0523 8486

e [info@jmgcranes.com](mailto:info@jmgcranes.com)



## Electric Pick & Carry Cranes



### MC 300S - Hydraulic Head (metric)

Max Capacity 30.000 kg

[www.jmgcranes.com](http://www.jmgcranes.com)

**JMG**<sup>®</sup>  
movetosolution

# MC 300S

- RADIO REMOTE CONTROLLED
- PROPORTIONAL TELESCOPIC BOOM
- FRONT-WHEELS DRIVE WITH COUNTER ROTATION
- FRONT COMPASS OUTRIGGERS
- HYDRAULIC HEAD
- REMOVABLE COUNTERWEIGHTS

### Optionals:

- HYDRAULIC WINCH
- MANUEL JIB
- MANUAL EXTENSION
- HYDRAULIC EXTENSION FOR HYDRAULIC HEAD
- NON-MARKING TIRES
- HYDRAULIC FORKS
- ATEX CONVERSIONS
- CUSTOMIZED PAINTING



## Technical features

Max Capacity kg	30.000	LMI	Electronic safe load indicator and tilting moment limiter
	Dimension mm		4820x2150x2219
Front-wheels drive. 2 electric motors AC 12 kW 96V. Insulation class H		Total Kg. 29.450 Removable counterweights Kg. 8.700	96 V - 1125 Ah 8 working hours
	Front n.4 superelastic 355x50-20" Rear n.4 superelastic 355x50-20"		

## Load charts

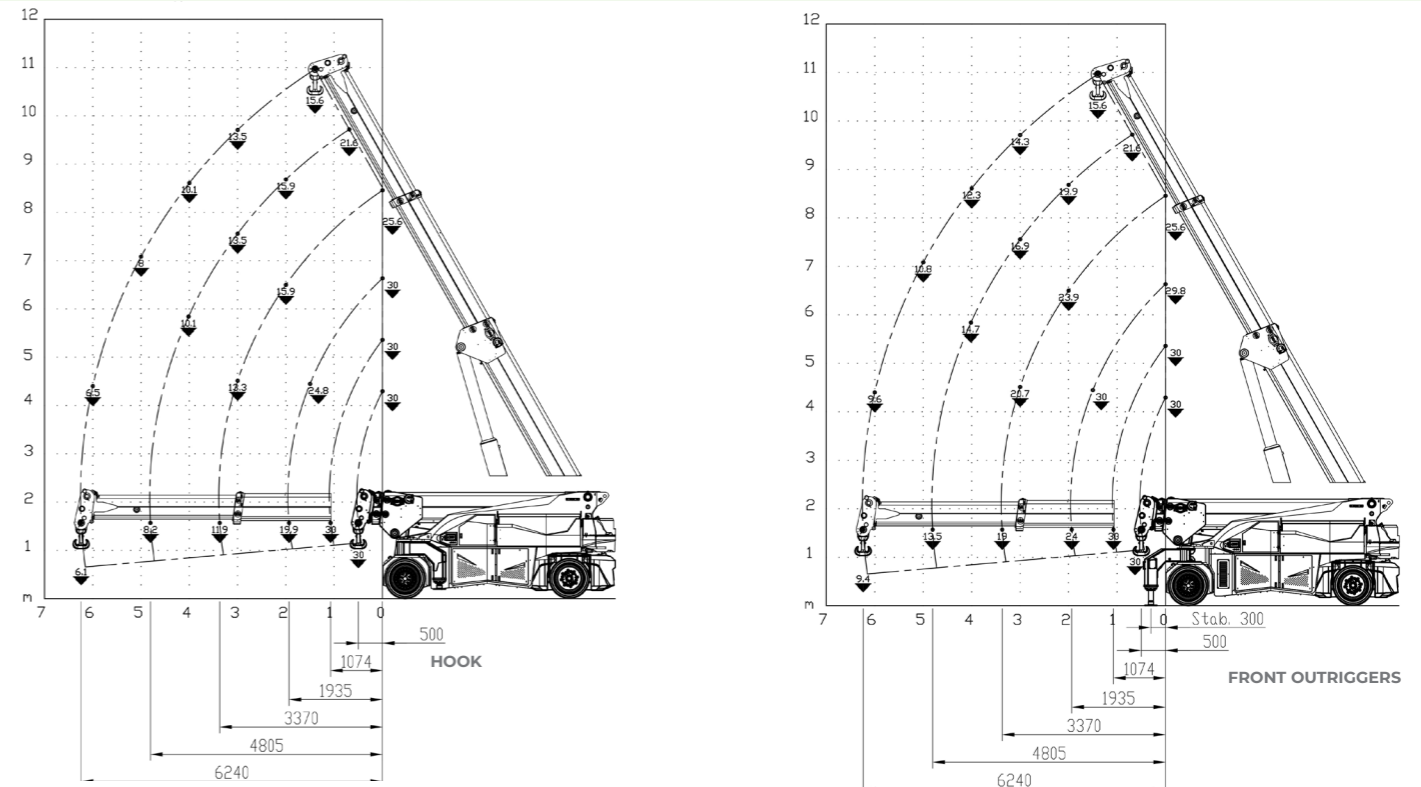

## EU Standards CE

	UNI ISO 4301-1: A1
	2006/42 CE-2014/30 UE-2014/35 UE- 2000/14 e and subsequent modifications
	EN 13000:2014 ANSI/ASME B30.5-2011 and subsequent modifications

## Dimension

